

QUARTZ 2000-3000

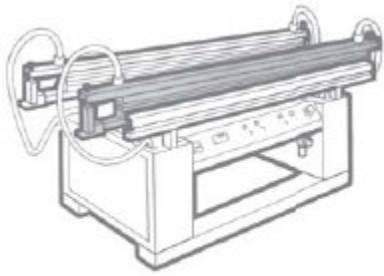

2000 2G

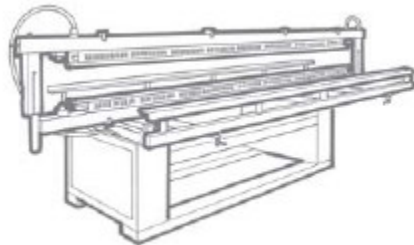

3000 1G

- Multibending - bilateral heating machine.
- Heating length 2000 mm and 3000mm
 - Heated area from 10 to 50 mm
 - Max. width 12-15 mm
 - Models with 1 - 2 - 3 - 4 units

TECNOLOGY FOR PLASTIC MATERIALS PROCESSING

The QUARTZ heater has been designed and built to heat plastic material so they can bend without streaking or burning the inside and outside of the material.

For this reason is equipped with two/four or more heating groups.

The QUARTZ heater has a well outlined irradiated area, which allows executing both radiused folds and checking the length of the radius.

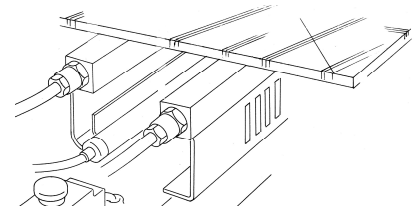

QUARTZ 2000

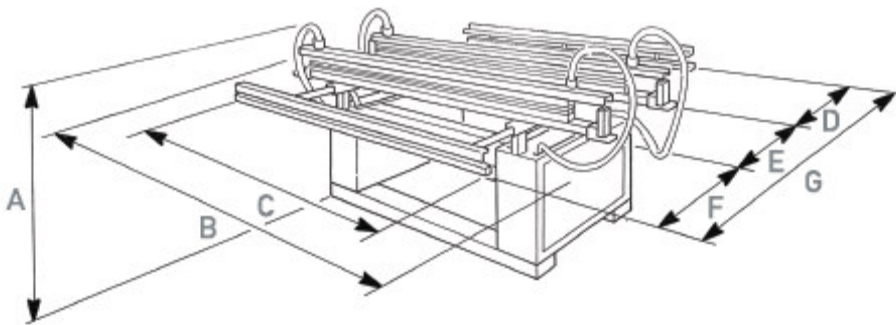

Description	U of measure	2G
A	mm	1200
B	mm	2000
C	mm	2500
D	mm	900
E	mm	1200
F	mm	900
G	mm	3000

Description	U of measure	2G
Feeling	Volt.	220
Max power	Watt.	6000
Heated area		Min. 10mmMax 50mm
Minimum centres between two folds		Min. 40mm
Air pressure	bar	3
Heating lenght	mm	2000
Weight	Kg.	250
Cooling		Obligatory



	A	B
1 Group 2 heating bars	Upper and lower heating	Two lower heating groups
2 Groups 4 heating bars (or more)	Upper and lower heating	Four lower heating groups

